

SERVICE BULLETIN

Beech

Kit No. 58-4008-1 S
Kit No. 58-4008-7 S

Kit No. 58-4008-3 S
Kit No. 58-4008-9 S

Kit No. 58-4008-5 S
Kit No. 58-4008-11 S

TITLE: FUSELAGE - WING FORWARD SPAR CARRY-THRU STRUCTURE INSPECTION AND/OR REINFORCEMENT

SYNOPSIS OF CHANGE

This Service Bulletin has been revised and is produced in the new format for Raytheon Aircraft Company Service Bulletins. Relevant technical changes are marked with change bars in the outside margins. The prior release of this Service Bulletin allowed for continued flight with known cracks that met specific criteria, and required a 500 flight hour recurring inspection. At the request of the Federal Aviation Administration (FAA), this Service Bulletin has been revised to remove the allowable crack limits that were permitted in prior releases of this Service Bulletin (SB No. 2269 and SB No. 2269, Rev. 1). If any crack(s) are discovered or are known to still be present from a previous inspection, this Service Bulletin revision requires that the crack(s) must be repaired by installation of the applicable P/N 58-4008 Kit(s) within the compliance times specified under ACCOMPLISHMENT INSTRUCTIONS in this Service Bulletin. If no cracks are discovered, this Service Bulletin revision continues to require re-inspection of the wing forward spar carry-thru structure forward and aft frames every 500 flight hours. The COMPLIANCE statement and ACCOMPLISHMENT INSTRUCTIONS for this Service Bulletin have been revised.

1. Planning Information

A. Effectivity

(1) Airplanes

(a) Civil

Beech Travel Air Model 95, B95, B95A, D95A and E95, Serials TD-1 through TD-721;

Beech Baron Model 95-55, 95-A55, 95-B55 and 95-B55A, Serials TC-1 through TC-349 and TC-351 through TC-2456;

Beech Baron Model 95-C55, 95-C55A, D55, D55A, E55 and E55A, Serials TC-350 and TE-1 through TE-1201;

Beech Baron Model 56TC and A56TC, Serials TG-1 through TG-94;

Beech Baron Model 58 and 58A, Serials TH-1 through TH-1475.

(b) Military

Beech Baron Model 95-B55B (T42A), Serials TF-1 through TF-70.

The export of these commodities, technology or software are subject to the US Export Administration Regulations. Diversion contrary to U.S. law is prohibited. For guidance on export control requirements, contact the Commerce Department's Bureau of Export Administration at 202-482-4811 or at www.bxa.doc.gov.

Raytheon Aircraft Company (RAC) issues Service Information for the benefit of owners and fixed base operators in the form of two classes of Service Bulletins. The first class, Mandatory Service Bulletins (red border) includes changes, inspections and modifications that could affect safety or crashworthiness. RAC also issues Service Bulletins with no red border which are designated as either recommended or optional in the compliance section within the bulletin. In the case of recommended Service Bulletins, RAC feels the changes, modifications, improvements or inspections will benefit the owner/operator and although highly recommended, Recommended Service Bulletins are not considered mandatory at the time of issuance. In the case of Optional Service Bulletins, compliance with the changes, modifications, improvements or inspections is at the owner/operator's discretion.

Both classes are mailed to:

- (a) RAC Authorized Service Centers.
- (b) Owners of record on the FAA Aircraft Registration Branch List and the RAC International Owner Notification/Registration Service List.
- (c) Those having a publications subscription.

Information on Owner Notification Service or subscription can be obtained through any RAC Authorized Service Center. As Mandatory Service Bulletins and Service Bulletins are issued, temporary notification in the Service Bulletin Master Index should be made until the index is revised. Warranty will be allowed only when specifically defined in the Service Bulletin and in accordance with the RAC Warranty Policy.

Unless otherwise designated, RAC Mandatory Service Bulletins, Service Bulletins and RAC Kits are approved for installation on RAC airplanes in original or RAC modified configurations only. RAC Mandatory Service Bulletins, Service Bulletins and Kits may not be compatible with airplanes modified by STC installations or modifications other than RAC approved kits.



AP-1260 M

Issued: August, 1989

Revised: June, 2004

Recurring Inspection

SB 53-2269, REV. 2

SERVICE BULLETIN

If you are no longer in possession of the airplane, please forward this information to the present owner.

(2) Spares

None.

B. Reason

This Service Bulletin is being issued to provide inspection and repair information relating to forward wing spar carry-thru structure forward and aft frames. Reports of frame (web) cracking have been received on in-service airplanes. If these cracks are detected at any time, the repairs described in this Service Bulletin should be applied.

C. Description

This Service Bulletin inspects the wing forward spar carry-thru structure forward and aft frames for cracks within the first 1500 flight hours of airplane service. If the airplane has over 1500 flight hours, the inspection is to be accomplished at the next scheduled inspection. If no cracks are found, the inspection is to be accomplished at recurring 500 flight hour intervals. The wing forward spar carry-thru structure forward and aft frames are first visually inspected and then further inspected using a dye-penetrant inspection. Prior releases of this Service Bulletin allowed for continued flight with known cracks that met specific criteria, and required a 500 flight hour recurring inspection. At the request of the FAA, this Service Bulletin has been revised to remove the allowable crack limits that were permitted in prior releases of this Service Bulletin. If any cracks are discovered or are known to still be present from a previous inspection, this Service Bulletin revision requires that the cracks must be repaired by installation of the applicable P/N 58-4008 Kit(s) within the compliance times specified under ACCOMPLISHMENT INSTRUCTIONS in this Service Bulletin. If no cracks are discovered, this Service Bulletin revision requires re-inspection of the wing forward spar carry-thru structure forward and aft frames every 500 flight hours.

D. Compliance

Airworthiness Directive AD 90-08-14 was issued on the matter covered by the prior release of this Service Bulletin (SB No. 2269, Rev. 1). A new or revised Airworthiness Directive is anticipated to be issued as a result of this FAA directed revision.

(1) Civil Airplanes

Raytheon Aircraft Company considers this to be a mandatory inspection/modification and it must be accomplished as soon as possible after receipt of this Service Bulletin, but no later than the first 1500 flight hours. If an airplane has over 1500 flight hours, it is to be accomplished at the next scheduled inspection. If no cracks are found, it should be repeated at 500 flight hour intervals thereafter. If cracks are found, the applicable P/N 58-4008 Kit(s) must be installed. Any airplane with known crack(s) in compliance with prior releases of this Service Bulletin (SB No. 2269) which allowed cracks must install the applicable P/N 58-4008 Kit(s). Compliance times for installation of the appropriate kits vary depending on length and location of cracks and are specified under ACCOMPLISHMENT INSTRUCTIONS in this Service Bulletin.

If the airplane must be moved to another location for repairs to be accomplished, a ferry permit may be obtained in accordance with 14 CFR Part 21.197 (a)(1) and 14 CFR 21.199 by contacting the FAA.

SERVICE BULLETIN

Any of the areas shown in Figure 1 that are modified by the installation of a doubler need not be inspected until 1500 flight hours after the installation of that particular doubler. If no cracks are found in the doubler, repeat the inspection of the doubler every 500 flight hours thereafter.

(2) **Military Airplanes**

For compliance information on military airplanes affected by this Service Bulletin, contact the appropriate headquarters.

E. Approval

The engineering data contained in this Service Bulletin is FAA approved.

F. Manpower

The following information is for planning purposes only:

Estimated man-hours for visual and dye-penetrant inspection: 4 hours (if accomplished in conjunction with an annual or routine inspection).

Estimated man-hours for modification: The man-hour determination will be based upon the findings of the inspection. Contact Raytheon Aircraft Company at 1-800-429-5372 or 316-676-3140 for assistance.

Suggested number of men: 1 man.

The above is an estimate based on experienced, properly equipped personnel complying with this Service Bulletin. Occasionally, after work has started, conditions may be found which could result in additional man-hours.

G. Weight and Balance

The weight and balance information for each airplane modified in accordance with this Service Bulletin must be adjusted in accordance with the kit drawing. It is the responsibility of the owner/operator to maintain compliance with the applicable Airworthiness Regulations.

H. Electrical Load Data

Not changed.

I. Software Accomplishment Summary

Not applicable.

J. References

The appropriate Section(s) or Chapter(s) of the applicable airplane Shop Manual, Maintenance Manual, Shop Manual Supplement and/or Maintenance Manual Supplement.

K. Publications Affected

It is recommended that a note "See Service Bulletin No. 53-2269, Rev. 2" be made in the following:

Beechcraft Travel Air 95 B95, B95A, D95A and E95 Illustrated Parts Catalog, P/N 95-590018B3 or subsequent, Figure 8;

Raytheon Aircraft Beech Baron B55, E55, and 58 (58A) Illustrated Parts Catalog, P/N 58-590000-19E10 or subsequent, Chapter 53-10;

SERVICE BULLETIN

Raytheon Aircraft Beech Baron 56TC and A56TC Illustrated Parts Catalog, P/N 96-590003-7B2 or subsequent, Figure 101;

Raytheon Aircraft Beech Baron 55, A55, B55 (B55A), C55 (C55A), D55 (D55A) and E55 (E55A) Illustrated Parts Catalog, P/N 96-590010-13B3 or subsequent, Chapter 53-17.

The appropriate Section(s) or Chapter(s) of the applicable airplane Illustrated Parts Catalog and/or Illustrated Parts Catalog Supplement.

L. Interchangeability of Parts

Not applicable.

M. Warranty Credit

None.

2. Material Information

A. Materials - Price and Availability

Contact a Raytheon Aircraft Authorized Service Center or RAPID for information.

B. Industry Support

Not applicable.

C. Airplanes

The following kits required for this modification may be ordered through a Raytheon Aircraft Authorized Service Center or RAPID:

Model/Serial	Part Number	Description	Quantity Per Airplane
Beech Travel Air - Model 95, B95, B95A, D95A and E95, Serials TD-1 through TD-721; Beech Baron - Model 95-55, 95-A55, 95-B55 and 95-B55A, Serials TC-1 through TC-1525 except TC-350 and TC-1471; Model 95-C55, 95-C55A, D55, D55A, E55 and E55A, Serials TC-350, TE-1 through TE-896; Model 56TC and A56TC, Serials TG-1 through TG-94; Model 95-B55B (T42A), Serials TF-1 through TF-70.	58-4008-1 S	Kit Information - Front Spar Carry-Thru Structure Reinforcement (Forward Frame)	1 required

SERVICE BULLETIN

Model/Serial	Part Number	Description	Quantity Per Airplane
Beech Travel Air - Model 95, B95, B95A, D95A and E95, Serials TD-1 through TD-721; Beech Baron - Model 95-55, 95-A55, 95-B55 and 95-B55A, Serials TC-1 through TC-1525 except TC-350 and TC-1471; Model 95-C55, 95-C55A, D55, D55A, E55 and E55A, Serials TC-350, TE-1 through TE-896; Model 56TC and A56TC, Serials TG-1 through TG-94; Model 95-B55B (T42A), Serials TF-1 through TF-70.	58-4008-3 S	Kit Information - Front Spar Carry-Thru Structure Reinforcement (Rear Frame)	1 required
Beech Baron - Model 58, 58A, Serials TH-1 through TH-303, except TH-255.	58-4008-5 S	Kit Information - Front Spar Carry-Thru Structure Reinforcement (Forward Frame)	1 required
Beech Baron - Model 58, 58A, Serials (TH-1 through TH-303, except TH-255.	58-4008-7 S	Kit Information - Front Spar Carry-Thru Structure Reinforcement (Rear Frame)	1 required
Beech Baron - Model 95-B55, Serials TC-1471, TC-1526 through TC-2456; Model E55, Serials TE-897 through TE-1201; Model 58, 58A, Serials TH-255, TH-304 through TH-1475.	58-4008-9 S	Kit Information - Front Spar Carry-Thru Structure Reinforcement (Forward Frame)	1 required
Beech Baron - Model 95-B55, Serials TC-1471, TC-1526 through TC-2456; Model E55, Serials TE-897 through TE-1201; Model 58, 58A, Serials TH-255, TH-304 through TH-1475.	58-4008-11 S	Kit Information - Front Spar Carry-Thru Structure Reinforcement (Rear Frame)	1 required

Raytheon Aircraft Company expressly reserves the right to supersede, cancel and/or declare obsolete, without prior notice, any kits, parts, or publications that may be referenced in this Service Bulletin.

SERVICE BULLETIN

CAUTION

All Raytheon Aircraft approved kits, unless otherwise designated, are approved for installation on Raytheon Aircraft airplanes in original or Raytheon Aircraft approved modified configurations only. Raytheon Aircraft approved kits may not be compatible with airplanes modified by STC installations or modifications other than Raytheon Aircraft approved kits.

D. Spares

Not applicable.

E. Reidentified Parts

None.

F. Tooling - Price and Availability

None.

3. Accomplishment Instructions

This Service Bulletin shall be accomplished as follows:

NOTE

Should any difficulty be encountered in accomplishing this Service Bulletin, contact Raytheon Aircraft Company at 1-800-429-5372 or 316-676-3140 for commercial aircraft, and appropriate headquarters for military aircraft.

A. Airplane**WARNING**

Observe all Warnings and Cautions contained in the aircraft manuals referenced in this Service Bulletin.

Whenever any part of this system is dismantled, adjusted, repaired or renewed, detailed investigation must be made on completion to make sure that distortion, tools, rags or any other loose articles or foreign matter that could impede the free movement and safe operation of the system are not present, and that the systems and installations in the work area are clean.

NOTE

Refer to the appropriate Section(s) or Chapter(s) of the applicable airplane Shop Manual, Maintenance Manual, Shop Manual Supplement and/or Maintenance Manual Supplement when accomplishing this Service Bulletin.

- (1) Remove all power from the airplane and disconnect the battery. Display warning notices prohibiting reconnection of airplane electrical power.

SERVICE BULLETIN

- (2) Remove the pilot's and copilot's seats and the carry-thru cover to obtain access to the front spar carry-thru structure.
- (3) Thoroughly clean the forward and aft frames (webs) of the front spar carry-thru structure in the shaded areas shown in Figure 1.
- (4) Perform a visual inspection of the area cleaned in step 3 for evidence of cracks.
- (5) Perform a dye penetrant inspection using visible dyes, of the area cleaned in step 3 for evidence of cracks.

NOTE

The first inspection must be performed no later than the first 1500 flight hours. If an airplane has over 1500 flight hours, the inspection is to be accomplished at the next scheduled inspection. If no cracks are found repeat the inspection every 500 flight hours.

NOTE

Any of the shaded areas shown in Figure 1 that are modified by the installation of a doubler need not be dye-penetrant inspected until 1500 flight hours after the installation of that particular doubler. If no cracks are found, repeat the inspection every 500 flight hours.

Cracks found in the shaded areas of Figure 1 that have not been modified by a doubler must be repaired as indicated in this Service Bulletin on an individual basis.

- (6) If cracks are discovered or if any cracks are known to still be present from a previous inspection, determine the methods of repair according to the following criteria:

NOTE

The extent of repair is limited to cracking in the radius of the web flange and cracks in the web flat areas at the fasteners of the lower front spar cap.

- (a) For cracks in the bend radius:
 - (i) A crack up to 4.0 inches in length shall be stop drilled at the ends using a #30 drill bit. The area is to be repaired per the applicable P/N 58-4008 Kit(s) within the next 100 flight hours, 12 calendar months or the next scheduled inspection whichever occurs first.

CAUTION

Caution must be used during the stop drilling operation. Do not drill into spar cap, skin, or any other structure. A thin steel plate may be used to prevent damaging adjacent structure.

- (ii) A crack exceeding 4.0 inches in length shall be repaired PRIOR TO FURTHER FLIGHT per the applicable P/N 58-4008 Kit(s).

SERVICE BULLETIN

- (b) For cracks in the web face, in the area of the huckbolt fasteners:
 - (i) A crack emanating from one fastener in two directions is considered to be one crack. **Do not stop drill, due to the possibility of damaging structure behind web face.**
 - (ii) Any crack shall be repaired per the applicable P/N 58-4008 Kit(s), within the next 25 flight hours, 12 calendar months or the next scheduled inspection whichever occurs first.
 - (iii) A crack passing through two fasteners and extending beyond for more than 0.5 inch on either end shall be repaired PRIOR TO FURTHER FLIGHT, per the applicable P/N 58-4008 Kit(s).
 - (iv) A crack passing through two fasteners and extending beyond for less than 0.5 inch on both ends shall be repaired per the applicable P/N 58-4008 Kit(s), within the next 25 flight hours, 12 calendar months or the next scheduled inspection whichever occurs first.

- (c) If cracks are found in both the forward and aft frames on the same side of the airplane, in either the web face and/or the bend radius, and any of the cracks are more than 1.0 inch long, a repair shall be made PRIOR TO FURTHER FLIGHT.

- (d) If cracks are found in both the forward and aft frames on the same side of the airplane, in either the web face and/or the bend radius, and all of the cracks are less than 1.0 inch long, a repair shall be made per the applicable P/N 58-4008 Kit(s) within the next 25 flight hours, 12 calendar months or the next scheduled inspection whichever occurs first.

- (e) If a fuselage skin crack is discovered around the opening for the lower forward carry-thru fitting, an external skin doubler may be required. Contact Raytheon Aircraft Company for further instructions.

- (7) Repair all cracks per the applicable P/N 58-4008 Kit(s).
- (8) Reinstall the carry-thru cover and the pilot's and copilot's seats.
- (9) Reconnect the airplane battery, remove warning notices and restore power.
- (10) Ensure all work areas are clean and clear of tools and miscellaneous items of equipment.
- (11) Return airplane to service.

B. Spares

Not applicable.

C. Record of Compliance

Upon completion of this Service Bulletin, make an appropriate maintenance record entry specifying the kit identification number and the kit serial number. It is recommended that the parts list contained in the kit be filed for future reference until the listing of parts has been incorporated into the Parts Catalog.

SERVICE BULLETIN

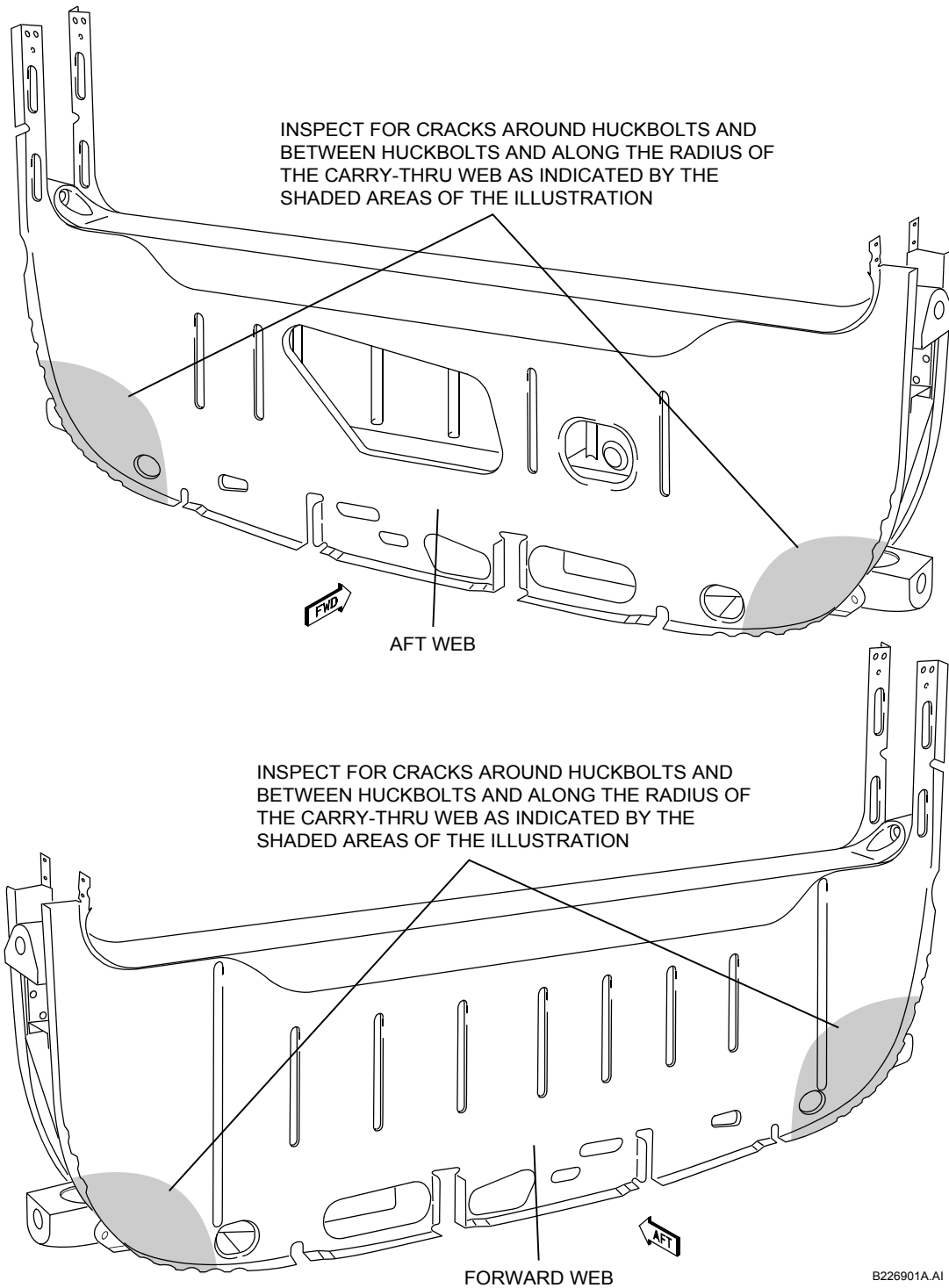

Inspection for Cracks in the Wing Forward Spar Carry-Thru Structure Forward and Aft Frames

Figure 1